



pelsis

*PRECISE.
POWERFUL.
DEPENDABLE.
WORLD-CLASS
EQUIPMENT.*

A FAMILY OF BRANDS WITH ONE SHARED PURPOSE

Our customers are on the front lines taking on pests, germs and other challenges that threaten peace of mind. That's why our products can't afford to fail. It's why we obsess over every detail and innovate with precise intention. Everything we do is to empower our customers with the best professional equipment in the world so they can get the job done to the highest potential.

WE ARE  **pelsis**

To find out more about the Pelsis Group and our brands, visit pelsis.com

B&G

CURTIS DYNA-FOG[®]

SYNERGETIC[®]

 **EDIALUX**
PROFESSIONAL PRODUCTS

NETWORK

P+L Systems[®]
Washroom

SILVANDERSSON 

AGRISENSE

BUILT ON A LEGACY OF BEING THE BEST IN PEST CONTROL.

We know how important the balance between control and extermination is. With our rich knowledge of the industry, history of innovative product development and expert technical support, our extensive product range is designed to ensure that pest professionals can select the right product for every pest problem. Our brands were born out of a need to create better equipment, and that same drive fuels our research, quality manufacturing and intentional innovation.

B&G

B&G designs and manufactures equipment based on in-depth knowledge of the pest control industry worldwide. The world-famous B&G tank sprayers have the highest quality stainless steel combined with special-grade brass, and chemical-resistant gaskets and hoses to provide durable and dependable service. They are the first choice of professionals throughout the pest control industry, with models to suit every application need.

CURTIS DYNA-FOG[®]

Known around the world for best-in-class disinfection and flying insect control equipment, Curtis Dyna-Fog continues to raise the bar. Their versatile catalog of products also features heavy-duty commercial foggers for large spaces, bird repelling and stored crops. Dyna-Fog equipment is trusted in nearly every corner of the world with endless versatility, dependable quality and masterful engineering.

SYNERGETIC[®]

Backed by patented technology and expert research, Synergetic[®] leads the flying insect control space in fly lights, bulbs and glue boards. Customers across North America stake their reputation on Synergetic products to rid spaces of flies, wasps and other flying insects. With innovative green light and LED technology, our products have been independently proven to attract a wider range of insects from farther distances.

CONTENTS.

08

SPRAYERS

- 10 Primeline Sprayers
- 12 Compact Sprayers
 - 12 AccuSpray Elite
 - 14 Spotsprayr
 - 14 QT-1 Sprayer
- 15 Specialty Sprayers
 - 15 Green Sprayer
- 16 Aerosol Delivery
 - 16 Aerosol Delivery Unit
 - 17 Portable Aerosol Systems
- 18 Sprayer Parts
- 22 Sprayer Accessories
 - 22 Pressurizing Tank Top
 - 22 Sprayer Caddy
 - 23 Comfort Grip
 - 23 Emergency Kits

24

FOGGERS

- 26 Hurricane ES
- 28 Hurricane Ultra
- 29 Cyclone Ultra
- 30 Tornado & Tornado Flex
- 32 My-Ti-Lite
- 32 Ultra-Lite 2400
- 33 Flex-A-Lite 2600
- 34 Backpacks
 - 34 Versa-Fogger
 - 35 Twister XL-3

36

DUSTERS & DUST APPLICATION

- 38 Bulb Duster
- 38 Mini Dust-R
- 39 Hand Dust-R
- 39 Long Reach Granular Dust-R
- 40 Electric
 - 40 110V Electric Duster
 - 40 VersaDuster
- 41 Duster Parts & Accessories

42

BAIT GUNS

- 44 Multi-Dose Bait Gun
- 45 Bait Gun Accessories

46

FOAMING EQUIPMENT

- 48 VersaFoamer HH
- 49 VersaFoamer 4000

50

TERMITE CONTROL

- 52 Wood Treatment System (WTS)
- 53 Termite Control Parts

56

FLY LIGHTS

- 58 Glue Board Fly Lights
 - 58 Infiniti
 - 60 Halo
 - 62 Edge
 - 63 Flytrap Professional
- 64 Specialty Flylight
 - 64 Halo Aqua
- 66 Decorative Fly Lights
 - 66 Halo Curve
 - 67 Nectar
 - 68 Luralite Professional
 - 69 Luralite CentoPlus
 - 70 Flypod
 - 71 Aura
- 72 Electric Grid Fly
 - 72 Allure
 - 73 Executor

74 FAQs

78 Product Selector

82

RODENT CONTROL

- 84 Fast-Catch
- 85 Rodent Control Parts

86

SERVICE CASES

SPRAYERS

PRECISE. POWERFUL. PROVEN.

Born from a need for better equipment, B&G Sprayers are the rock of the professional pest control industry. Trusted by pros around the world, our equipment is crafted to be dependable, easy to repair and versatile for any challenge on the job. Choose from our complete line to add the most reliable sprayers and accessories available to your operation.



PRIMELINE SPRAYERS

PRIMELINE SPRAYERS
ICONIC FOR A REASON.

The B&G Primeline is known as the most reliable sprayer in pest control. Designed for years of dependable service, this iconic sprayer has the highest quality stainless steel combined with special-grade brass and chemical-resistant gaskets and hoses to take down any challenge, year after year. They are the first choice of professionals throughout the pest control industry, with models to suit every application need.

FEATURES

- .5-, 2-, 3-gallon and 5-liter capacity
- 9-inch, 18-inch and 24-inch extensions



PRIMELINE SPRAYERS

EXTENDA-BAN

FEATURES

- Extenda-Ban: Top quality valve for instant tip shut-off
- B&G 4 Way Tip: With fine fan, coarse fan, pin stream and either a Crack & Crevice Straw orifice (CC) or a second pin stream (S)

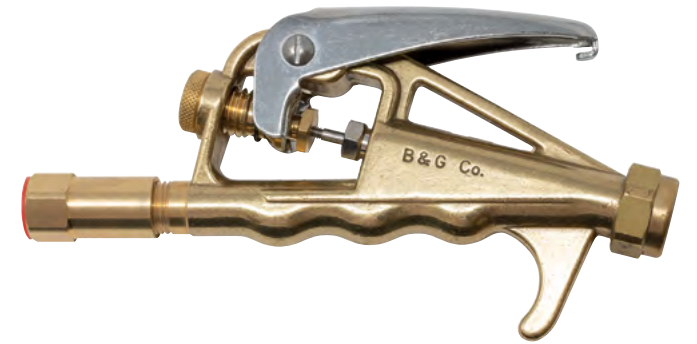

EXTENDA-BAN AND NEXT GENERATION VALVE

TANK CAPACITY	EXTENSION	MODEL #	ORDER #
1/2 Gallon	9"	N74-CC	11003275
1 Gallon	9"	N124-CC	11003900
1/2 Gallon	9" without C+C	N74-S	11003200
1 Gallon	9" without C+C	N124-S	11003500
1/2 Gallon	18"	N74-CC-18	11003285
1 Gallon	18"	N124-CC-18	11003950
2 Gallon	18"	N224-CC	11004300
1/2 Gallon	18" without C+C	N74-S-18	11003225
1 Gallon	18" without C+C	N124-S-18	11003700
2 Gallon	18" without C+C	N224-S	11004200
1 Gallon	24"	N124-CC-24	11003924
2 Gallon	24"	N224-CC-24	11004375

BAN-DRIP

TANK CAPACITY	EXTENSION	MODEL #	ORDER #
1/2 Gallon	-	N64-CC	11002090
1 Gallon	-	N114-CC	11002600

COMPACT SPRAYERS

Lighter and more portable, our compact sprayers go everywhere you go with ease.

ACCUSPRAY ELITE THE FUTURE IS HERE.

The AccuSpray compact sprayer (16 oz) is a great tool to bring along for any commercial or residential pest control job and is a terrific complement to the standard B&G tank sprayer. Use the crack-and-crevice straw and/or atomizing spray to treat the less-accessible, hard-to-reach spaces.

FEATURES

- Comes with a carry pouch that attaches to your belt
- Valve inserts into pouch for added convenience
- AccuSpray Elite model features stainless-steel bottle and heavy-duty hose
- Brass Extenda-Ban valve
- Wide variety of tips



ACCUSPRAY ELITE - NEXT GENERATION VALVE

- Light weight non-slip valve
- Made from Durable Polymer

COMPACT SPRAYERS

ACCUSPRAY ELITE - 4 WAY TIP WITH CRACK AND CREVICE STRAW AND NEXT GENERATION VALVE

- Light weight non-slip valve
- Made from Durable Polymer



ACCUSPRAY ELITE

ITEM #	DESCRIPTION	MODEL #	ORDER #
1	AccuSpray with Push-Button Trigger Valve	-	24000040
2	AccuSpray Elite - 4 Way Tip with C+C Straw	-	24000100
3	AccuSpray Elite - Next Gen Valve, 4 Way Tip with C+C Straw	-	24000200
4	AccuSpray Elite C+C Straw Only	-	24000102
5	AccuSpray Elite - Termite Injection Tip	-	24000101
6	Tip Kit for AccuSpray with Push-Button Trigger Valve	-	24000031
7	Spare Bottle and Cap	-	24000115
8	Gasket Kit for AccuSpray Elite	-	24000037
9	Repair Kit (AccuSpray)	-	24000001

COMPACT SPRAYERS

SPOTSPRAYR

The sprayer for all specialty chemical applications.

FEATURES

- Chemical-resistant seals
- All metal bottle with brass spray tip
- Pin-to-cone nozzle
- High efficiency pump
- Belt holster



SPOTSPRAYR

ITEM #	DESCRIPTION	MODEL #	ORDER #
1	SpotSprayR	-	24000107

QT-1 SPRAYER

The perfect spot sprayer for all specialty chemical applications.

FEATURES

- Ideal for applying microbial cleaners or other chemicals
- Liquid and foaming models - 1.5 liter capacity
- Great for spot treatments
- Viton® seals



SPOTSPRAYR

ITEM #	DESCRIPTION	MODEL #	ORDER #
1	QT-1 with FN-2280 Foam Tip	-	17017408
2	QT-1 with 6" Plastic Straw	-	17017404
3	QT-1 with SST Inject Tip	-	17017403
4	QT-1 with Adjustable Pin-to-Cone Tip	-	17017401
5	QT-1 with Fan Tip	-	17017407

SPECIALTY SPRAYERS

Get a sprayer for specific applications or to easily identify organic, natural or specialty chemicals.

GREEN SPRAYER

Can be used with natural products, most common insecticides and non-repellant type products.

FEATURES

- Models with 9-inch or 18-inch extensions available
- Chemical-resistant hose
- B&G 4 Way Tip
- Green top and carpet protector ring



GREEN SPRAYER

ITEM #	DESCRIPTION	MODEL #	ORDER #
1	Green Sprayer 9" Extension, CC 4-Way Tip	-	11003917
2	Green Sprayer 18" Extension, CC 4-Way Tip	-	11003958

AEROSOL DELIVERY

Defined by ultra-fine, consistent droplets, aerosol sprayers ensure efficient and accurate delivery.

AEROSOL DELIVERY UNIT

FEATURES

- Works with *BASF™ products
- Promotes professional image
- Attaches to can top with no leakage
- Easy to use on/off valve
- 6-foot coiled hose
- Sure seal design

HOLSTERS

- Chemical and wear resistant material
- Belt loop for easy access
- Pockets to hold straws



AEROSOL DELIVERY UNIT

ITEM #	DESCRIPTION	MODEL #	ORDER #
1	BASF™ (WIT) / Standard	ADUWM	24000050
2	BASF™ (WIT) / Deluxe-Brass HDL	ADUWM	24000076
3	Standard Holster	-	24000073
4	Deluxe Holster	-	24000072

AEROSOL DELIVERY

PORTABLE AEROSOL SYSTEM (PAS)

Modern pest control requires more than one application method. Get deep wall penetration, along with crack-and-crevice and localized fogging capabilities in one ideal tool. The B&G ULV Portable Aerosol System is designed for adaptability, giving operators the option to integrate liquid and aerosol products in one application, or make use of each delivery method individually.



PORTABLE AEROSOL SYSTEM (PAS)

ITEM #	DESCRIPTION	MODEL #	ORDER #
1	PAS with 9" Extension	-	16290000
2	PAS with 18" Extension	-	16300000
3	Commercial PAS with 9" Extension	-	16270000
4	Commercial PAS with 18" Extension	-	16400000

FEATURES

- Can be adjusted for delivery of a very fine ULV fog to a heavy mist to handle most applications
- 1-gallon tank can be removed from case for cleaning or filling
- Brass and stainless-steel gun with choice of 9-inch or 18-inch extension, 10-foot coiled hose on standard model
- Delivers both water- and oil-based formulations with low to moderate viscosity
- 10-foot hose provides mobility
- Adjustable flow rates: 4-10 oz/min
- At maximum flow rate (gauge 30 psi), droplet size is 40-50 microns, droplet throw 15 feet with effective distance of 10 feet
- Coverage: 20 sq ft (at 30 psi)

PORTABLE AEROSOL SYSTEM (PAS), CART MOUNTED

FEATURES

- Three-gallon stainless tank for extra capacity
- 15-foot coiled hose
- 18-inch stainless steel extension and tip
- Delivers both water- and oil-based formulations with low to moderate viscosity
- Adjustable flow rate: 4-10 oz/min
- At maximum flow rate (gauge 30 psi) droplet size is 40-50 microns, droplet throw 15 feet with effective distance of 10 feet
- Coverage: 20 sq ft (at 30 psi)



PORTABLE AEROSOL SYSTEM (PAS), CART MOUNTED

ITEM #	DESCRIPTION	QTY PER CASE	MODEL #	ORDER #
5	Cart-mounted PAS with 18" Extension	1	-	12011030

SPRAYER PARTS

Find B&G Sprayer Parts to upgrade or rebuild your equipment. Our tanks and sprayers are expertly engineered for maximum compatibility and easy repairs.

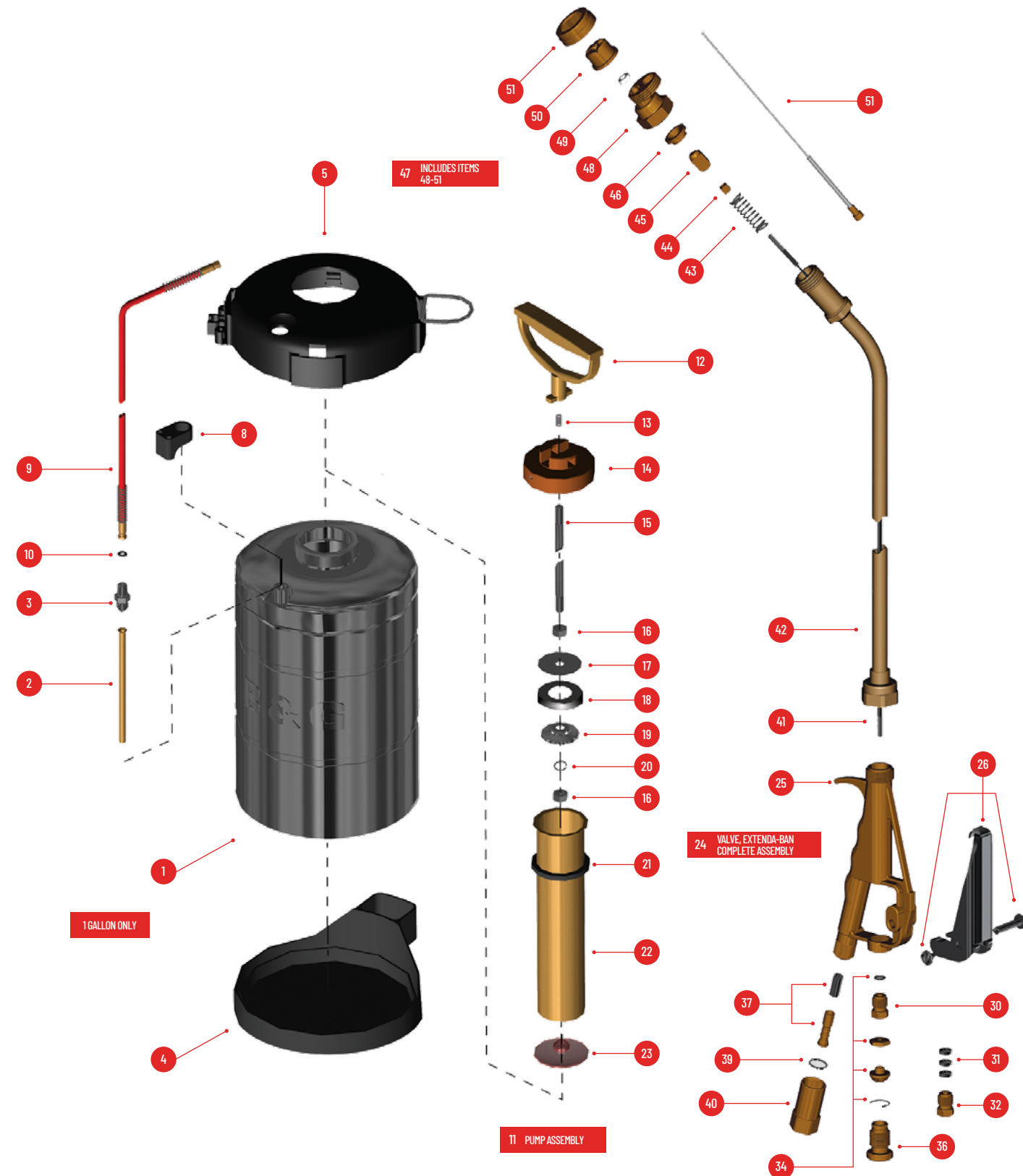

ITEM #	PART #	ORDER #	DESCRIPTION
1	T-50	22024800	Tank (.5 Gallon)
	T-100	22025000	Tank (1 Gallon)
	T-200	22025100	Tank (2 Gallon)
	T-300	22025200	Tank (3 Gallon)
	T-500	22025250	Tank (5 Liter)
2	HS-297	22025600	Tube, Siphon (.5 Gallon)
	OS-297	22025700	Tube, Siphon (1 Gallon)
	TS-297	22025800	Tube, Siphon (2 Gallon)
	THS-297-01	22025901	Tube, Siphon (3 Gallon)
	FS-297	22025950	Tube, Siphon (5 Liter)
3	HA-298	22025300	Adapter, Hose
4	TB-1	22049477	Bottom, Tank (1 Gallon Only)
5	TT-1	22049476	Top, Tank (1 Gallon Only)
8	5700-H	22049475	Holder, Tip (Not used with Item 5)
9	D-50	22030100	Hose, 4 ft., red
10	D-51-P	22030400	Washer, Hose
11	PH-265	22026900	Pump Assembly (.5 Gallon)
	PO-265	22027000	Pump Assembly (1 Gallon)
	PF-265	22027125	Pump Assembly (2 Gallon and 5 Liter)
	PT-265	22027100	Pump Assembly (3 Gallon)
	12	P-275	22029800
13	P-276	22029900	Spring, Pump Lock
14	P-274	22029700	Cap, Pump
15	PH-273	22029400	Rod, Plunger (.5 Gallon)
	PO-273	22029500	Rod, Plunger (1 Gallon)
	PF-273	22029650	Rod, Plunger (2 Gallon and 5 Liter)
	PT-273	22029600	Rod, Plunger (3 Gallon)
	16	P-269-SS	22028250
17	P-272	22029200	Plate, Back
18	NP-277	22029000	Cup, Polypropylene
	NP-271	22028800	Cup, Leather
19	NP-270	22028600	Plate, Cup Spreader
20	P-269A	22028400	Washer, Lock
21	P-268	22028000	Gasket, Pump
22	PH-267	22027400	Tube, Pump (.5 Gallon)
	PO-267	22027500	Tube, Pump (1 Gallon)
	PF-267	22027650	Tube, Pump (2 Gallon and 5 Liter)
22	PT-267	22027600	Tube, Pump (3 Gallon)

ITEM #	PART #	ORDER #	DESCRIPTION
23	PV-266	22027200	Valve, Check
24	120	22042101	Valve, Extenda-Ban 9" (less tip)
	220	22042203	Valve, Extenda-Ban 18" (less tip)
	420	22042778	Valve, Extenda-Ban 24" (less tip)
25	VB-147	22044450	Valve Body Kit
26	VT-140	22042800	Trigger, Valve Housing, Screw
28	-	22025150	Stainless siphon tube, pump cylinder
30	PN-150-2	22042455	Nut, Packing
30A	PN-150-1	22042454	(1999 - 2000) Nut, Packing
31	VP-151	22045099	Packing, Valve
32	PN-150	22044900	Nut, Packing (Prior to 1999)
34	AS-148	22044500	Adjusting Screw, Lock nut, Snap ring
36	SL-162	22046700	Nut, Safety Lock
37	MS-145-50	22043800	Strainer, 50 Mesh Support, Strainer
39	NG-146	22044200	Gasket, Nylon
40	SA-143	22043400	Housing, Strainer
41	VC-152	22045300	Cable, Valve 9"
	VC-153	22045400	Cable, Valve 18"
	VC-163	22045450	Cable, Valve 24"
42	VE-154	22045500	Extension, Brass 9"
	VE-155	22045600	Extension, Brass 18"
	VE-164	22045650	Extension, Brass 24"
	VE-154-SS	22045510	Extension, Stainless Steel 9"
	VE-155-SS	22045610	Extension, Stainless Steel 18"
	VE-164-SS	22045710	Extension, Stainless Steel 24"
43	VS-156	22045700	Spring, Seat Stem
44	SSL-157	22045900	Nut, Seat Stem
45	SS-158	22046100	Stem, Seat
46	SP-159	22046300	Gasket, Soft Seat
47	5850-CC	22049466	B&G 4 Way C&C Tip Assembly (Parts 48-51)
	5850	22049451	Tip Assembly (No C+C)
48	9751-M	22049300	Holder, B&G 4 Way C+C Tip
49	4190	22034700	Gasket, Viton®
50	5800-CC	22049467	Tip, B&G 4 Way C+C
	5800	22049452	Tip only (No C+C)
51	4596	22034500	Retainer, Tip
52	5700-B	22049200	Extension, C+C

SPRAYER PARTS

NOZZLES



STRAWS AND NEEDLES

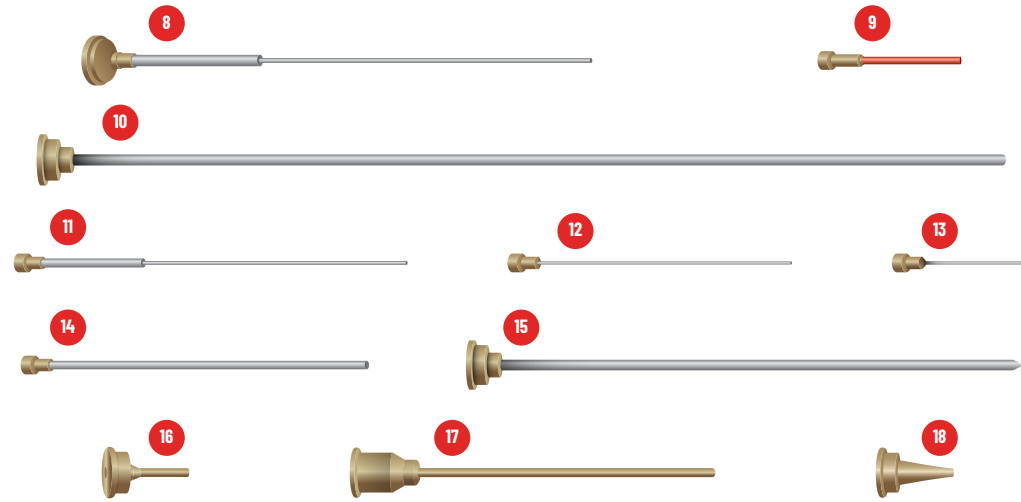

19 TREATMENT VOLUME METER (TVM)

- Attaches to hose and valve
- Measures ounces or ml applied
- Total volume for each account
- Data transferred to smart phone
- Long-lasting battery, 1 hr. charge



20 9" NEXT GEN VALVE WITH BRASS TIP

- Stainless-steel core
- Stainless steel extension
- Brass nozzle
- High-density polymer grip



21 18" NEXT GEN VALVE WITH TIP

- Stainless-steel core
- Stainless steel extension
- Brass nozzle
- High-density polymer grip



SPRAYER PARTS

ITEM #	DESCRIPTION	PART #	ORDER #
Tip Assemblies			
1	B&G 4 Way C+C Tip Assembly (complete)	5850-CC	22049466
2	B&G 4 Way Tip Assembly (complete)	5850	22049451
3	Pin-to-Cone (other sizes available)	5500-Y-2	22036600
4	Adjustable Pin-to-Cone	AV-210	22083602
Nozzles			
5	B&G 4 Way C+C Tip	5800-CC	22049467
6	B&G 4 Way Tip Only (no C+C orifice)	5800	22049452
Straws & Needles			
8	Plastic C+C Straw (fits directly on a gun with a 1325 Tip Cap)	100-CC	22049500
9	1" plastic C+C Straw (fits in B&G 4 Way C+C tip)	1603	22071703
10	Ban-Drip Fan Tip (3/16" dia., 12" long) (requires 1325 Tip Cap)	1052	22039677
11	6" plastic C+C Straw (fits in B&G 4 Way C+C Tip)	5700-B	22049200
12	3.5" Stainless Steel Injector Needle (fits in B&G 4 Way C+C Tip)	5700-SS	22049400
13	2" Stainless Steel Void Tip (fits in B&G 4 Way C+C Tip)	5700-2	22071785
14	4" Stainless Steel 4 Way Void Tip (fits in B&G 4 Way C+C Tip)	5701	22049425
15	8" Mulch/Ant Mound Probe (fits any gun/ext. with 1325 Tip Cap)	100-8	22071684
16	1" Wood Injection Tip (requires 1325 Tip Cap)	Whit-1	22071824
17	4" Wood Injection Tip (requires 1325 Tip Cap)	Whit-4	22071827
18	.5" Wood Injection Tip (requires 1325 Tip Cap)	Wood Tip	24040077
Treatment Volume Meter (TVM)			
19	Treatment Volume Meter (TVM)	-	22046810
Next Gen Valve			
20	9" Next Gen Valve with Brass Tip	-	22042301
21	18" Next Gen Valve With Tip	-	22042401

SPRAYER ACCESSORIES

Take your sprayer to the next level with specialized accessories. Whether you need added mobility, accuracy or power—we have the accessories you're looking for.

PRESSURIZING TANK TOP (PTT) UPGRADE TO UNSTOPPABLE.

FEATURES

- Attaches to top of B&G tanks
- Maintains 30 psi in tank
- Constant pressure to empty tank
- Long-lasting battery, 4 hr. charge/25-30 gals per charge



PRESSURIZING TANK TOP

ITEM #	DESCRIPTION	MODEL #	ORDER #
1	Pressurizing Tank Top	-	22046000

SPRAYER CADDY

Mounts in service vehicle and holds Primeline sprayers firmly in place. Helps prevent damage or chemical spillage during transportation.

FEATURES

- Heavy duty metal construction
- Chip resistant finish
- Mounting holes for either side or bottom mounting



ITEM #	DESCRIPTION	MODEL #	ORDER #
1	Caddy - 1 gallon and 5 liter - tall	-	11009850
2	Caddy - 2, 3 gallon and 5 liter - short	-	11009860

SPRAYER ACCESSORIES

1 COMFORT GRIP

- Reduce fatigue
- Non-slip grip
- Identify product in the spray tank
- Great for replacements



6 TECHNICIANS EMERGENCY KIT

Commonly needed parts for most B&G equipment. Includes easy to understand drawings of parts, repair hints, and refill quantities. Works in conjunction with the Office Emergency Kit as a refilling station.



4 - 7 FIRST AID KITS

Same as the Gasket Kit but includes higher volumes of all parts. Good for conducting Care & Maintenance classes for an entire office.



7 OFFICE EMERGENCY KIT

Contains more quantities of those parts in the Technician Emergency Kit and also has many less common parts not included in the Technician Emergency Kit. Recommended for office supply rooms. Good for offices with 3 to 8 technicians. Includes easy to understand drawings of parts, repair hints, and refill quantities.

ITEM #	DESCRIPTION	PART #	ORDER #
Comfort Grip			
1	Comfort Grip Handle	GT-100	22029800
Kits			
3	Sprayers with Next Generation Valve	GD-124X	22050101
4	Sprayers with Extenda-Ban Valve and Next Generation Valve	FA-600-D	22050400
5	Sprayers with Ban-Drip Valve	FA-600-B	22050300
6	Technician Emergency Kit	TE-125	23088125
7	Office Emergency Kit	OE-126	23088126

FOGGERS

**UNBEATABLE PERFORMANCE.
UNRIVALED QUALITY.**

Our foggers sit in a class of their own, with user-friendly innovation and unmatched coverage. Proven through constant testing and development, Curtis Dyna-Fog and B&G foggers continue to raise the bar for efficacy in disinfection, pest control and flying insect control.



HURRICANE ES

ELECTROSTATIC EFFICIENCY WITH CONSISTENT COVERAGE.

PORTABLE ELECTROSTATIC AEROSOL APPLICATOR (ULV/MISTER)

ELECTROSTATIC TECHNOLOGY

The Hurricane ES™ utilizes electrostatic technology to charge each droplet to provide effective application of formulations. The droplets stay separated due to the charged nature allowing uniform coverage on the entire target surface.

DISPENSES WATER-BASED PRODUCTS

The Hurricane ES™ is ideal for use in spraying commercial and residential areas. Hotels, schools, greenhouses, warehouses, medical facilities, sanitation, germicidal treatments and disease control programs are markets where the Hurricane ES™ is used.

FEATURES

- Precision flow rate and droplet control
- Uniform and consistent coverage
- Droplet size can be controlled for both ULV and residual spraying
- Stainless-Steel Metering Valve

COMMONLY SPRAYED SOLUTIONS

- Insecticides
- Disinfectants
- Deodorizers
- Fungicides
- Odor Neutralizers
- Water (Humidification)
- Germicides
- Poultry Vaccines

SPECIFICATIONS

ADJUSTABLE FLOW RATES	0-6.6 oz/min (3 gal/hr)
DROPLET SIZE	10-50 microns (VMD)
DROPLET THROW	15 ft
COVERAGE	60-80 sq ft
ELECTROSTATIC THRESHOLD DISTANCE	12-18 in from the front of the fogger
TANK CAPACITY	1 gallon (3.8 liters)
DIMENSIONS	H 14 in / W 10 in / L 11.5 in
WEIGHT	6.6 lbs (empty)



HURRICANE ES

ITEM #	DESCRIPTION	MODEL #	ORDER #
1	110/120 volt AC, 6.8 Amps, 50/60 Hz	3001-5 Hurricane ES 110V	62150-3
2	220/240 volt AC, 3.4 Amps, 50/60 Hz	3001-6 Hurricane ES 220V	62150-4

HURRICANE ULTRA II

The Hurricane Ultra II is a premier choice for industrial and residential areas—from farms, greenhouses and warehouses to disinfection and disease control programs. Its chemical-resistant precision nozzle and low-profile, sturdy tank make the Hurricane Ultra II both functional and incredibly reliable.

FEATURES

- Rugged design handles corrosive liquids and heavy impacts.
- Dispenses both oil- and water-based formulations
- Solid stainless-steel metering valve for delivering precise outputs and maximizing use of chemicals
- Low profile tank design virtually eliminates tipping...empty or full!
- Droplet sizes can be controlled for both ULV spraying and residual spraying.
- Hurricane Ultra II will replace the Hurricane, Hurricane Ultra, Sanitizer and Anileator. Anileator orifice kit must be purchased separately and installed. Anileator orifice kit part # 62234.

COMMONLY SPRAYED SOLUTIONS

- Insecticides
- Disinfectants
- Deodorizers
- Fungicides
- Odor Neutralizers
- Water (Humidification)
- Germicides
- Poultry Vaccines

SPECIFICATIONS

ADJUSTABLE FLOW RATES — 00-6.6 oz/min (3 gallons/hour)
 DROPLET SIZE — 10-50 microns
 COVERAGE FOR WATER-BASED APPLICATION — 60-80 sq ft
 TANK CAPACITY — 1 gallon (3.8 liters)
 DIMENSIONS — H 14 in / W 12 in / L 12 in
 WEIGHT — 6.6 lbs (Empty)

PRECISION NOZZLES

- Uniform and consistent coverage
- Three precision nozzles for greater output
- Chemical-resistant for maximum reliability

1-GAL TANK

- Translucent for easy visual reference
- Corrosion & impact resistant
- Low-profile design virtually eliminates tipping

6-FT ELECTRIC POWER CORD INCLUDED



HURRICANE ULTRA II

ITEM #	DESCRIPTION	MODEL #	ORDER #
1	110/120 volt AC, 6.8 Amps, 50/60 Hz	Hurricane Ultra 2 120V	62150-1
2	220/240 volt AC, 3.4 Amps, 50/60 Hz	Hurricane Ultra 2 240V	62150-2

CYCLONE ULTRA

The Cyclone Ultra has a 2-stage blower and metering valve assures particles under 20 microns regardless of flow rate. Ideal for areas such as hospitals, nursing homes, schools, apartment buildings, restaurants and greenhouses.

The Cyclone Ultra can apply pesticides, deodorants, fungicides, duct sealant, disinfectants and miticides, efficiently and economically. The Cyclone can be used in indoor/outdoor applications requiring 5-20 micron droplets.

FEATURES

- Delivers both water- and oil-based formulations with moderate to high viscosity

SPECIFICATIONS

ADJUSTABLE FLOW RATES — 1.4-3.1 oz/min, 0.6-1.5 gal/hr
 DROPLET SIZE — 8-10 microns, droplet throw 8-12 ft (formulations with high viscosity have larger droplets, 20-24 microns)
 BLOWER — Continuous duty, 200,000 rpm with replaceable brushes
 TANK SIZE — 1-gal tank
 WEIGHT — 9.3 lbs (empty)

MICROTEC™ NOZZLE

- Creates small, consistent droplets
- Apply disinfectant without wiping
- Reliably disinfect heavily trafficked areas

6-FT ELECTRIC POWER CORD INCLUDED



METERING VALVE

- Allows for easy control of output and droplet size

1-GAL TANK

- Translucent for easy visual reference
- Corrosion & impact resistant

CYCLONE ULTRA

ITEM #	DESCRIPTION	MODEL #	ORDER #
1	Cyclone Ultra 110 Volt	2734	62250-1
2	Cyclone Ultra 220 Volt	2736	62250-2

TORNADO, TORNADO FLEX

The multi-range Tornado has a 3 gallon tank for extended use, large formulation filter with removable screen and a precision metering valve that allows outputs from a mist of 5 gallons per hour down to ULV range. Ideal for humidification control in greenhouses and application of germicides and disinfectants. These foggers can be used to apply pesticides, deodorants, fungicides, disinfectants, and duct sealant. Treatment sites include hospitals, schools, resorts, food processing plants, warehouses, and dairy, poultry, and horse facilities.

FEATURES

- Delivers both water- and oil-based disinfectant formulations with moderate to high viscosity
- Precision metering valve
- Outputs from a mist of 5 gal/hr down to ULV range

SPECIFICATIONS

INPUT POWER	110/120 V AC, 8.5 amps, 50/60 Hz; 210/250 V AC, 4.2 amps, 50/60 Hz (model 3004)
ADJUSTABLE FLOW RATES	2.4-11.4 oz/min, 1.1-5.3 gal/hr
FLOW RATE	0-18.5 LPH
DROPLET SIZE	5-40 microns
TANK CAPACITY	3 gallon (11.4 liters)
WEIGHT	Tornado: 18.8 lbs (empty) Tornado Flex: 20 lbs (empty)

TORNADO FLEX

- 18-in flexible hose for directional application and precision



PRECISION NOZZLE

ADJUSTABLE TILT LOCKING KNOB

3-GAL TANK

- Large capacity for extended use
- Translucent for easy visual reference
- Corrosion & impact resistant

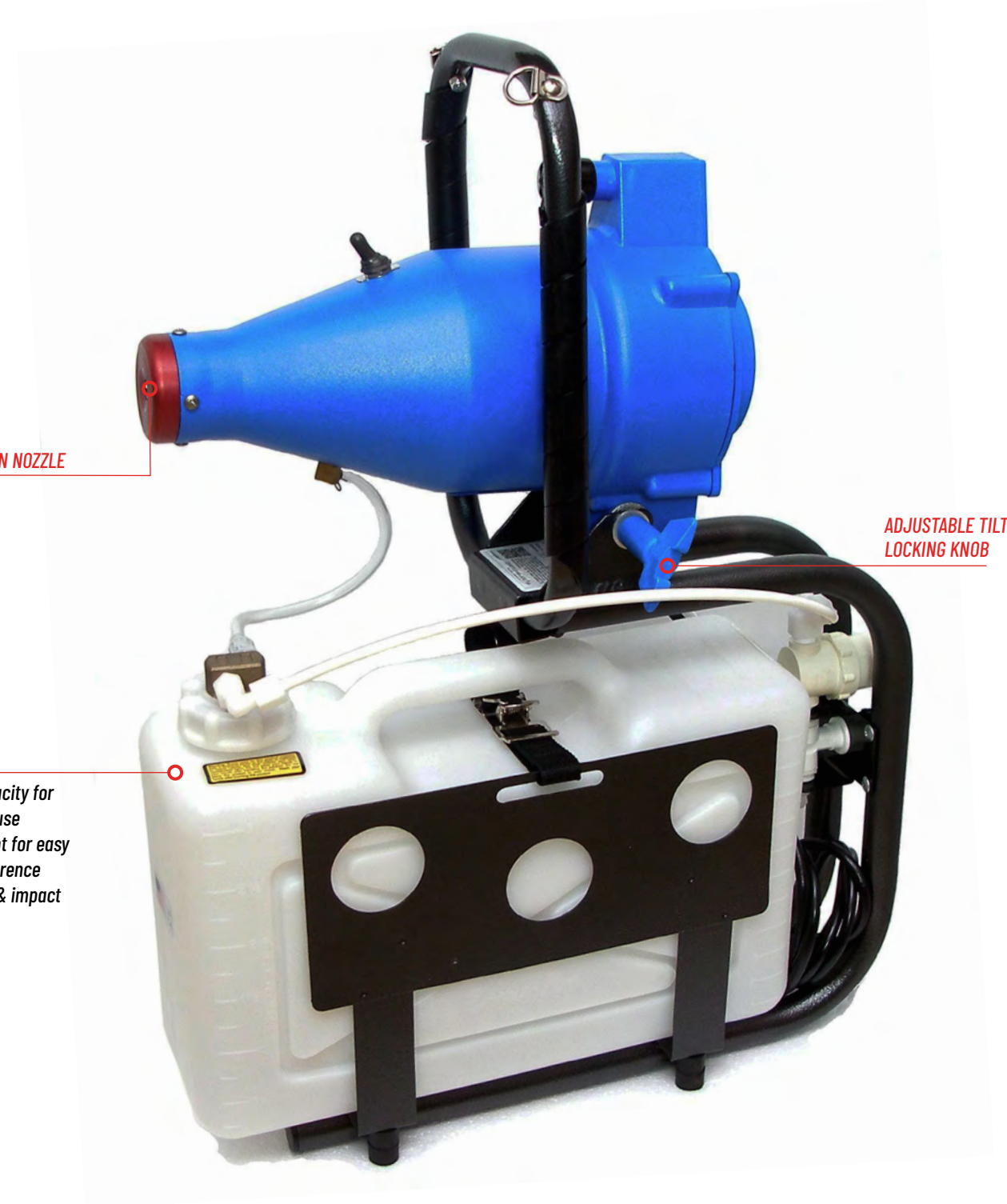

TORNADO, TORNADO FLEX

ITEM #	DESCRIPTION	MODEL #	ORDER #
1	Tornado 110 Volt	2895	62380
2	Tornado 220 Volt	2897	62382
3	Tornado Flex 110V	Series 2	63800-2

MY-TI-LITE 2300

FEATURES

- Ideal for general treatment with insecticides and sanitizers
- Flow rate approximately 9 ounces/minute
- Non-adjustable
- Non-ULV



MY-TI-LITE 2300

ITEM #	DESCRIPTION	MODEL #	ORDER #
1	My-Ti-Lite Fogger	2300	15015000

ULTRA-LITE 2400

FEATURES

- Adjustable flow rate up to 2.5 ounces/minute
- Variable delivery from ULV droplets to mist
- Droplets from ULV (20-35 microns) to power mist (56 microns)



ULTRA-LITE 2400

ITEM #	DESCRIPTION	MODEL #	ORDER #
1	Ultra-Lite Fogger	2400	15015100

FLEX-A-LITE 2600 A REPUTATION OF EXCELLENCE.

With its brawny construction and rugged dependability, the Flex-A-Lite 2600 sets the industry standard for heavy-duty point-and-spray foggers. A 1.5-gallon tank and four sturdy feet make it ideal for most industrial, sanitization and janitorial applications. Each fogger is individually built and tested for performance.

FEATURES

- Delivers both water- and oil-based formulations with moderate viscosity
- Available with 110V or 220V connections

SPECIFICATIONS

HOSE	18 in
TANK SIZE	1.5-gal tank
ADJUSTABLE FLOW RATES	0-9.4 oz/min, 0-4.4 gal/hr
DROPLET SIZE	ULV (20-35 microns) to power mist (56 microns), droplet throw 15 ft
COVERAGE	40 sq ft at high application setting
WEIGHT	9 lbs (empty)
DIMENSIONS	H 12 in / W 8.5 in / L 15 in



ULTRA-LITE 2400

ITEM #	DESCRIPTION	MODEL #	ORDER #
1	Flex-A-Lite Fogger	2600	15014901

BACKPACK FOGGERS

Put on a backpack fogger and bring power everywhere you go. Reliable and extremely mobile, our backpacks let applicators accurately disinfect or fog any spot they need.

VERSA-FOGGER

The Versa-Fogger provides 20-35 micron ULV droplets and 56 micron power mist droplets. Portable and powerful, Versa-Fogger is designed for a wide variety of applications from mosquito control and insect control to disinfection. With mobility, range and precision, this backpack fogger fully covers every target. Its heavy-duty construction, along with a deluxe backpack harness, will give you years of dependable service.

FEATURES

- Delivers both water- and oil-based formulations
- Reliable Honda 4 stroke motor - No need to mix oil with the gas
- Emissions compliant motor
- 1-gallon, pressurized formulation tank
- Adjustable handheld nozzle
- Three stage rotary blower
- Lightweight - less than 26 lbs (empty)
- .67 quart fuel capacity
- 2-year motor warranty (1-year other components)

SPECIFICATIONS

ENGINE	—————	Honda 4-stroke
SYSTEM	—————	Gasoline-powered backpack
HOSE	—————	4 ft
TANK SIZE	—————	1-gal tank
WEIGHT	—————	26 lbs (dry weight)
ADJUSTABLE FLOW RATES	———	1.5-6 oz/min (interchangeable nozzles)
DROPLET SIZE	—————	33-44 microns (oil-based formulations provide 20 micron droplets), effective droplet throw 10-12 ft
DIMENSIONS	—————	H 22.5 in / W 12 in / L 14.7 in
SHIPPING DATA	—————	H 16 in / W 19 in / L 26 in; 36 lbs; 4.39 cu ft

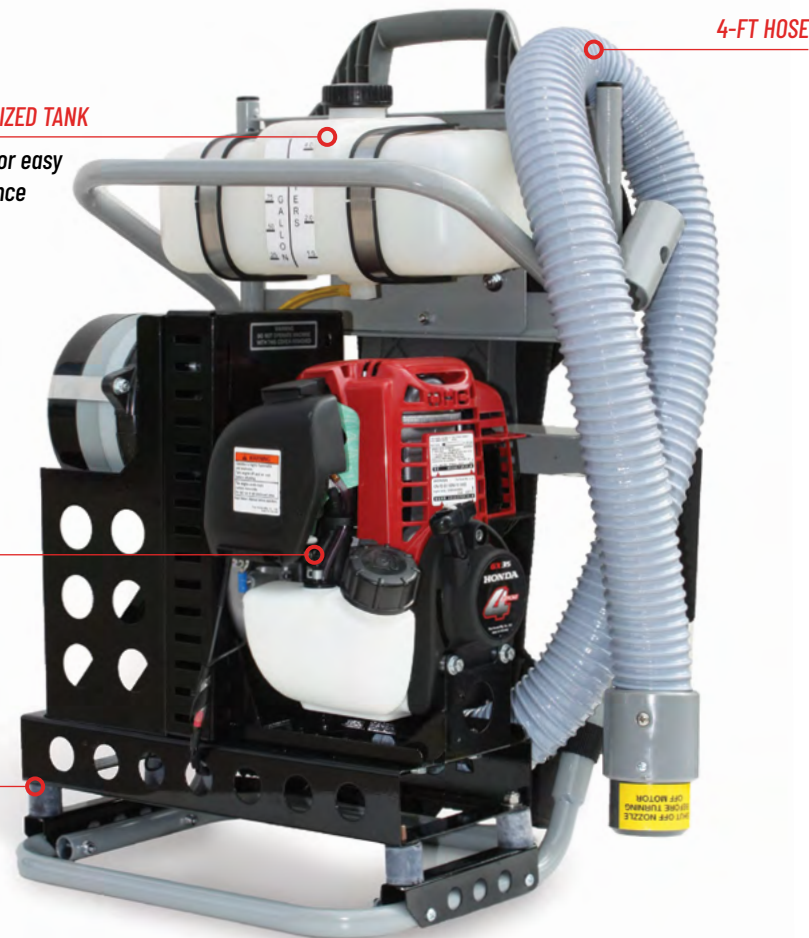

4-STROKE MOTOR

- Gasoline powered
- Low emissions and high performance
- 0.67 qt fuel capacity
- No need to mix oil with the gas

1-GAL PRESSURIZED TANK

- Translucent for easy visual reference

HEAVY-DUTY ISOLATORS

- Reduce engine vibration

4-FT HOSE

ULTRA-LITE 2400

ITEM #	DESCRIPTION	MODEL #	ORDER #
1	Versa-Fogger	-	45000000

BACKPACK FOGGERS

TWISTER XL-3 COMPACT DESIGN WITH POWER ABOVE ITS WEIGHT CLASS.

MOTORIZED KNAPSACK ULV SPRAYER

When you have a lot of ground to cover, you want the most advanced and sophisticated backpack fogger on the market. The Twister XL3 features a remarkable nozzle and blower system that outperforms competitors in value, durability and performance in open-air spaces like stadiums and amphitheatres. Compact, lightweight and designed to minimize engine vibrations, the Twister XL3 is ergonomically suited for extended use.

FEATURES

- Delivers both water- and oil-based formulations
- 4-stroke engine with low emissions and high performance
- 1-gallon pressurized formulation tank

LIGHTWEIGHT FRAME

THREE-STAGE ROTARY BLOWER

4-STROKE MOTOR

- Gasoline powered
- Low emissions and high performance
- 0.67 qt fuel capacity
- No need to mix oil with the gas

HEAVY-DUTY ISOLATORS

- Reduce engine vibration

4-FT HOSE



MICROTEC™ NOZZLE

- Highest flow rates in the industry
- Optional twin nozzles

ULTRA-LITE 2400

ITEM #	DESCRIPTION	MODEL #	ORDER #
1	Twister XL 3	-	39750

DUSTERS & DUST APPLICATION

ACCURATE APPLICATION IN ANY SPACE.

Our versatile line of dusters feature products for all dust applications from commercial kitchens to bed bug treatments.



BULB DUSTER

FEATURES

- Excellent for granule or dust applications
- Flexible base on extensions for hard-to-reach areas
- Extra tip extension for hard-to-reach areas
- Extension doubles as siphon tube if needed
- All plastic tips for application around electrical outlets
- Belt clip



BULB DUSTER

ITEM #	DESCRIPTION	MODEL #	ORDER #
1	Bulb Duster	1150	11005810

MINI DUST-R

FEATURES

- Chamber holds 0.5 lb. of dust, 7 oz. of granules
- Consistent delivery of granules
- Tip kit is stored inside the plunger tube

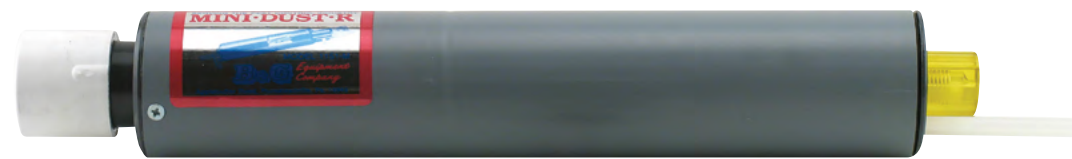

MINI DUST-R

ITEM #	DESCRIPTION	MODEL #	ORDER #
1	Mini Dust-R	1151-M	11005850

HAND DUST-R

FEATURES

- Chamber holds 2 quarts of dust
- Extension adds a static charge to the dust
- Ideal for treating attics and crawl spaces
- Includes 12 inch extension with 90° off-set at end of the tube
- Variety of tips included



HAND DUST-R

ITEM #	DESCRIPTION	MODEL #	ORDER #
1	Hand Dust-R	1152-A	11005800

LONG REACH GRANULAR DUST-R

FEATURES

- Chamber holds 2 quarts of dust
- Ideal for treating attics and crawl spaces
- Great for treating wasp nests
- 3-14 inch extensions
- Extension adds a static charge to the dust



LONG REACH GRANULAR DUST-R

ITEM #	DESCRIPTION	MODEL #	ORDER #
1	Long Reach Granular Dust-R	1153-G	24050000

ELECTRIC DUSTERS

Take on any target without pumping and get dust exactly where you need it.

110V & 220V ELECTRIC DUSTERS

FEATURES

- Chamber holds 3 lbs. of dust or granules
- Extension adds a static charge to the dust
- Flexible 1-foot hose to direct material to target
- Available in 110V or 220V



110V ELECTRIC DUSTER

ITEM #	DESCRIPTION	MODEL #	ORDER #
1	110V Electric Duster	2250	15015605
2	220V Electric Duster	2250/220v	15015610
3	12" Extension	2259	29108459

VERSADUSTER

Great for all dust applications from commercial kitchens to bed bug treatments.

FEATURES

- No batteries required
- XR Valve
- Works with all dust formulations
- Easily plugs into any power source
- "No Clog" design applies a dust application with each pull of the trigger
- Available as a kit (without compressor) for use with a PAS or Versafoamer
- Heavy duty fan cooled compressor unit for long service life. Electrical connection is made by use of a standard extension cord.
- Adjustment knob to control dust output.



VERSADUSTER

ITEM #	DESCRIPTION	MODEL #	ORDER #
1	Versaduster System Complete-110V	-	24010900

DUSTER PARTS/ACCESSORIES

Extra parts for added versatility and upgraded applications. Find the right duster parts for your equipment.

1 TIP KIT

- Can be used as extensions for many of our dust and granular products
- All plastic construction



2 VERSADUSTER TIP KIT



3 VERSADUSTER KIT

Now use a PAS or Versafoamer as a power duster. Comes as a complete kit and simply plugs in. Great for commercial kitchens or bed bug treatments.



4 SPARE BOTTLES AND TIPS

The Versaduster comes with a large and small dust bottle and a variety of tips.



ITEM#	DESCRIPTION	PART #	ORDER #
1	Tip Kit	DB-KIT	11005811
2	Versaduster Tip Kit	-	24010904
3	Kit (no compressor)-Use with PAS or Versafoamer	-	2401901
4	Spare Bottles and Kits	-	2401902

BAIT GUNS

THE RIGHT AMOUNT OF BAIT WITH PINPOINT PRECISION.

B&G bait guns are adjustable to release precise amounts of bait without spilling excess liquid. With durable construction and accessories for efficient unloading, B&G bait guns will stay in your arsenal for years to come.



MULTI-DOSE BAIT GUN

FEATURES

- Consistent delivery with each trigger pull
- Works with most baits
- Range of bait placement sizes available from calibrated knob
- Precision application of gel baits for cockroach and ant control
- Prevents over application, saving you money
- Deluxe bait holster available



MULTI-DOSE BAIT GUN

ITEM #	DESCRIPTION	MODEL #	ORDER #
1	Multi-Dose Gun Kit-Includes gun, extra syringe and syringe tip	3000	24020001
2	Multi-Dose Basic Kit- Gun with no accessories	3000-B	24020002
3	Multi-Dose Gun Deluxe Kit-includes model 3000 and holster	3000-DL	24020000

BAIT GUN ACCESSORIES

1 BAIT GUN HOLSTER

- Removable tube in holster keeps holster clean from accidental bait drips
- Pocket in front for needles and tips
- Straps on each side for extra bait tubes
- Velcro belt strap
- Heavy duty military grade nylon



2 REPLACEMENT TUBES (5)



ITEM #	DESCRIPTION	MODEL #	ORDER #
1	Bait Gun Holster	-	24020040
2	Replacement Tubes (5)	-	24020041

FOAMING EQUIPMENT

THOROUGH COVERAGE IN ALL THE RIGHT SPOTS.

Adding foam applicators to your operation ensures complete coverage to rid spaces of termites and other unwanted pests. Perfect for commercial accounts, B&G foaming equipment is portable and includes a durable case.



VERSAFOAMER HH

FEATURES

- Hand-pump to pressurize and make foam
- Great for wall voids and drains
- Excellent for termites, ants or small flies
- No adjustments, makes great foam every time
- Most parts interchangeable with standard B&G parts



OPTIONAL TIPS

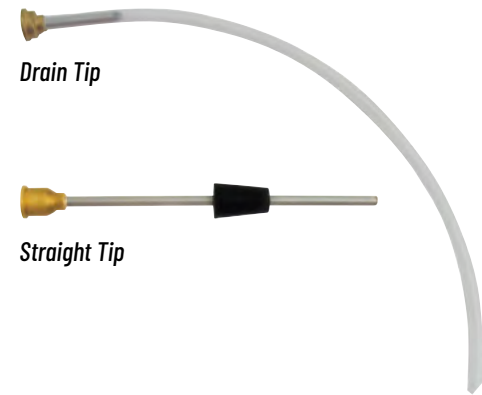

VERSAFOAMER HH

ITEM #	DESCRIPTION	MODEL #	ORDER #
1	Versafoamer HH	HH	11007360
2	Repair Kit	GT-100	22049600
3	Optional Drain Tip	-	16200023
4	Optional Straight Tip	-	16200018
5	Curved Tip (included with unit)	-	16200013

VERSAFOAMER 4000

The B&G Versafoamer 4000 is an easy-to-use power foamer and can be used in a wide variety of foaming applications. It's made of heavy-duty components and designed for years of dependable service.

FEATURES

- Electric, compressed-air system
- 1-gallon tank with pressure gauge
- Contained in leak-proof case
- No adjustments, great foam every time
- Quiet compressor motor, 7-foot hose



ULV PORTABLE AEROSOL SPRAYER VERSAFOAMER COMBO UNIT

Combine a PAS with a Versafoamer 4000 to create a flexible pest control system. Use one case and compressor and easily change out tank and valve for each different application.



ITEM #	DESCRIPTION	MODEL #	ORDER #
1	Versafoamer 4000	-	16201003
2	Versafoamer 220v	-	16201002
3	Commercial PAS-9" Extension with Versafoamer 4000	-	16500009
4	Commercial PAS-18" Extension with Versafoamer 4000	-	16500018
5	Standard PAS-9" Extension with Versafoamer 4000	-	16600009
5	Standard PAS-18" Extension with Versafoamer 4000	-	16600018

TERMITE CONTROL

BIG TIME TERMITE TREATMENT.

When it comes to termites, efficiency is everything. That's why B&G Termite Control products are designed for more volume and more tank capacity than typical foamers.



WOOD TREATMENT SYSTEM (WTS)

The B&G Wood Treatment System produces 10-15 times the volume of liquid as compared to a traditional foamer and 5 times more capacity as compared to typical fan sprays.

FEATURES

- Delivers liquid or foam insecticide
- 3-gallon tank, 30-foot or 50-foot hose
- Compressor maintains tank pressure, adjustable to 50 psi
- Ideal for pre-treatments of structural wood, sub-slab re-treatments for termites
- 220V Models available. Contact B&G for more information



WOOD TREATMENT SYSTEM (WTS)

ITEM #	DESCRIPTION	MODEL #	ORDER #
1	WTS-Standard 30' of hose, single surface tip and wall void tip	-	24040000
2	WTS-Deluxe 50' hose, cart handle extender, single 6" surface tip, wall void tip, dual 10" surface tip, and pressure injection tip	-	24040001

TERMITE CONTROL PARTS

Get tips, valves, pipes and more parts to make your termite control equipment unstoppable.

SERIES 400 TERMITE TOOL MODELS

Termite Tool Models are based on the valve (Versagun, Versatool, or Robco) and on the no-drip feature. A check-valve at the end of the 7/16 rods provides no-drip. These Models are 415, 425, and 435. The 410, 420, and 430 Models do not have the check valve. All Models come with a valve, a set of three stainless steel pipes (one .625 inch, and two .4375 inch), a Foot Ram for the .4375 inch diameter pipe, and a Tip Kit (4 tips).

- 4 precision delivery tips included
- Quick-change adapters on all pipes
- Meet current labeling requirements of termiticides
- Tip shut-off available on models 415, 425, 435

1 - 3 VERSAGUN

- Light-weight aluminum
- Balanced trigger for less operator fatigue



4 - 6 ROBKO QCG

- Pressure gauge port at valve
- Converts to a perimeter spray gun



7 - 10 VERSATOOL

- Economical and durable



11 - 13 PIPES

- All soil and sub-slab pipes are stainless steel
- Variety of lengths for all applications
- Comes complete with foot ram assembly

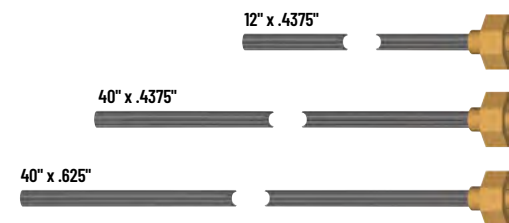

TIPS (included with each Termite Tool Model)

- Two sub-slab tips, one straight tip, and one soil tip for .625 inch pipe
- Stainless steel construction
- Nozzle flow rate calibrated at 20 psi

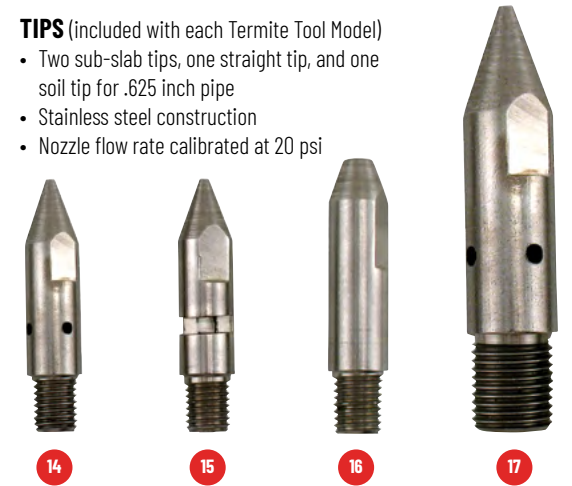

ITEM#	DESCRIPTION	MODEL #	ORDER #
-------	-------------	---------	---------

Tip Assemblies

1	Versagun Model: pipes and Tip Kit, no tip shut-off	430	11007430
2	Versagun Model: pipes and Tip Kit with tip shut-off	435	11007435
3	Versagun valve only		11007406
4	Robco Model: pipes and Tip Kit, no tip shut-off	420	11007420
5	Robco Model: pipes and Tip Kit with tip shut-off	425	11007425
6	Robco valve only		22067700
7	Versatool Model: pipes and Tip Kit, no tip shut-off	410	11007410
8	Versatool Model: pipes and Tip Kit with tip shut-off	415	11007415
9	Slab Injector: .625 dia. 40 in. pipe, foot plate, no tip shut-off	484	11007375
10	Versatool valve only		11007407

Pipes

11	12" x .4375"	-	22071427
12	40" x .4375"	-	22071428
13	40" x .625"	-	22071429

Termite Tips

14	360° - .4375" pipe	451	11007451
15	180° - .4375" pipe	453	11007453
16	Void Tip - .4375" pipe	457	11007457
17	360° - .625" pipe	454	11007454

TERMITE CONTROL PARTS

1 - 4 OPTIONAL TERMITE TOOL TIPS AND EXTENDA-PIPES

• Fits All Series 400 Termite Tools



.4375" x 40" Model # 460



.625" x 40" Model # 465

SUB-SLAB INJECTORS AND SOIL RODDING TOOLS

Sub-slab injectors are for application beneath concrete floor to reach the void below, or to treat through tile or wood flooring to reach a void or space beneath the concrete floor. The injection hole through the substrate is sealed with an expandable rubber gasket. Each Injector Kit has two directional tips (180 and 360 degrees). The tips have 2 gallon / minute flow rate and check valve provides tip shut-off. The Sub-Slab injector #6 is 28 in high and ideal for treating in narrow spaces, the Sub-Slab injector #7 is 18 in high.



Included with SSI- and SSI-14

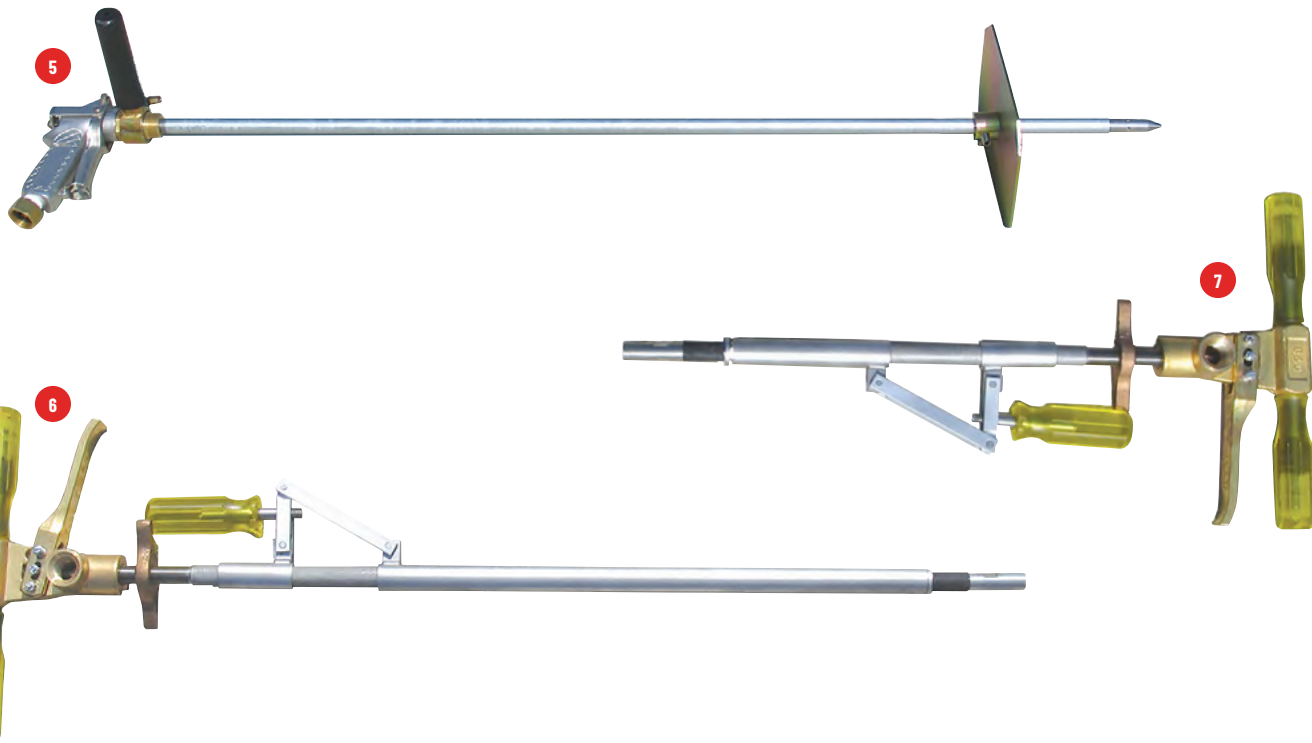

TERMITE CONTROL PARTS

TREBOR® TRIPLE SEAL

The most effective and easiest plug to install for termiticide applications. A hollow core and three flexible lips allow this patented plug to conform to hole irregularities better than solid core plugs. Available in three sizes. Hole size clearly marked on top to eliminate errors.

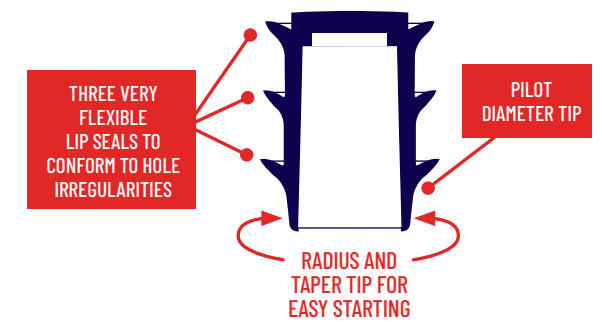
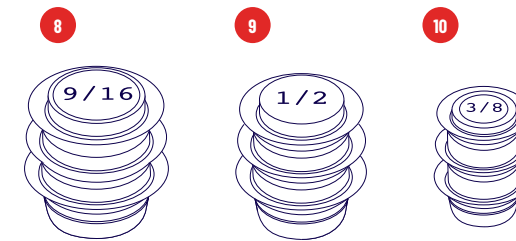

ITEM#	DESCRIPTION	PART #	ORDER #
Optional Termite Tool Tips and Extenda-Pipes (Fits All Series 400 Termite Tools)			
1	360 degree Tip	450	11007450
2	180 degree Tip	452	11007452
3	.625" x 40" Pipe	465	11007465
4	.4375" x 40" Pipe	460	11007460
Sub-Slab Injectors and Rodding Tools			
5	Robco Soil Rodding Tool .625" 360 delivery tip, 40 in. pipe, foot plate	-	22067703
6	Sub-Slab Injector SSI-14 28 in. high	-	11005985
7	Sub-Slab Injector - SSI-4 14 in. high	-	11005965
Trebor® Triple Seal			
8	.5625 Seal - 1 case (10 Buckets of 250 Seals)	4-562-505	45000562
9	.5 Seal - 1 case (10 Buckets of 250 Seals)	4-500-504	45000500
10	.375 Seal - 1 case (10 Buckets of 250 Seals)	4-375-504	45000375

RODENT CONTROL

OUTSMART RODENTS WITH DISCRETION AND SIMPLICITY.

B&G rodent control stations do all the work for you. Use non-fatal bait to monitor activity or a combination of bait and snap-trap for final control.



RODENT CONTROL

FAST-CATCH RODENT CONTROL DOWN TO A "T."

The Fast Catch can be used for monitoring with non-toxic bait and then when activity is present a snap trap can be used for final control. It can also be utilized as a "stand alone" snap trap or rodent bait station.

The Fast Catch station is available in two models: Station-only design, and a Rodent Alert design. The Rodent Alert stations feature a 'pop-up alert' that indicates when the snap trap inside the station has been triggered.

FEATURES

- Heavy duty construction
- Easy open single lock design
- Reusable - designed for years of service
- Tamper resistant - lid recesses into base
- Low profile design for increased rodent activity
- Fits all professional rat snap traps and includes bait rods
- Pop-outs in rear of station allows for attachment

PLACES TO USE

- Sensitive Accounts - where rodenticide is banned
- Residential Accounts - keeps rats hidden from occupants
- Commercial kitchens, restaurants and office complexes



RODENT CONTROL

RODENT STATION ATTACHMENT SYSTEM

FEATURES

- The station attachment system consists of 2 clamps, a metal screw and washer. It is designed for use with a 12 inch x 12 inch (1.5 inch thick) concrete paver, and only with B&G rodent stations
- Easy and economical way to secure the Fast Catch and rodent bait station
- Holds station securely to block and is reusable pop up alert

SPECIFICATIONS

- Attaches any B&G rodent station to a 12 inch x 12 inch paver block
- Installs in less than 30 seconds
- Heavy duty metal construction

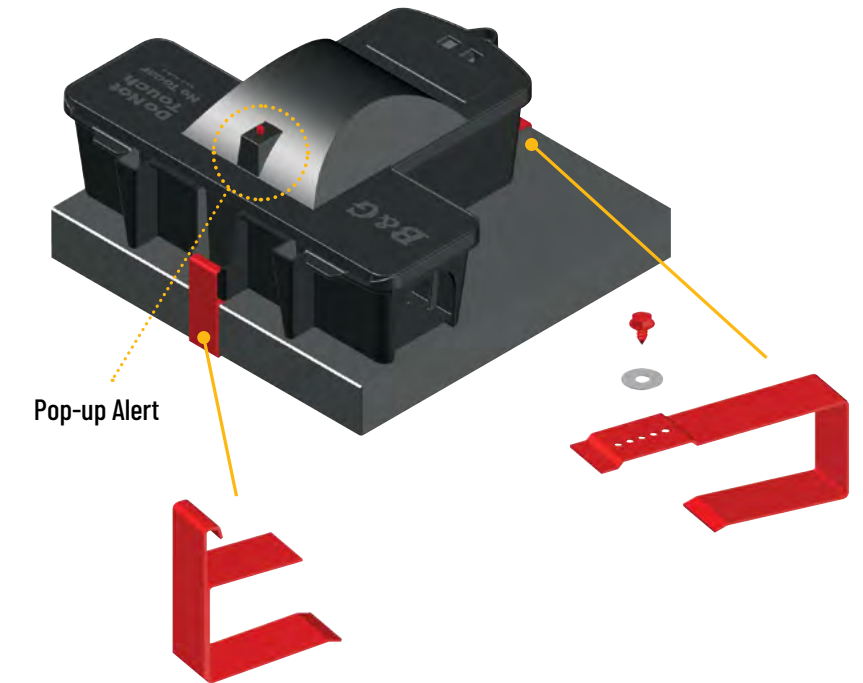

ITEM #	DESCRIPTION	MODEL #	ORDER #
1	Fast Catch Station with Rodent Alert	-	25000309
2	Fast Catch Station	-	25000308
3	Fast Catch 6 Pack with Attachment System	-	35000308
4	Fast Catch Alert 6 Pack with Attachment System	-	35000309

RODENT CONTROL PARTS

ITEM #	DESCRIPTION	MODEL #	ORDER #
1	Extra Key Pack - 15 Keys	-	25000205
2	Attachment System Kit	-	5000260-C

TECHNICIAN'S SERVICE CASES

PORTABLE CASES DESIGNED TO FIT INTO ANY SERVICE VEHICLE.

FEATURES

- Rotationally molded heavy-duty construction
- Molded in pockets to hold aerosols, dust bulbs, and AccuSpray products
- Open area for bait guns, monitors, flashlights or other tools
- Available as a plain case with no interior pockets
- Literature holder in rear of case
- Ergonomic design
- Compact—measures 13 inch x 13 inch x 14 inch high
- Variety of colors available
- Additional colors available: blue, red, black and green



Private label here

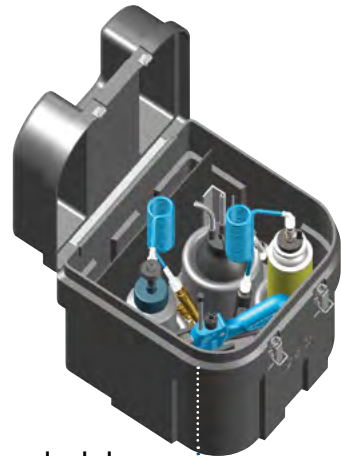

Case shown loaded with separately sold products

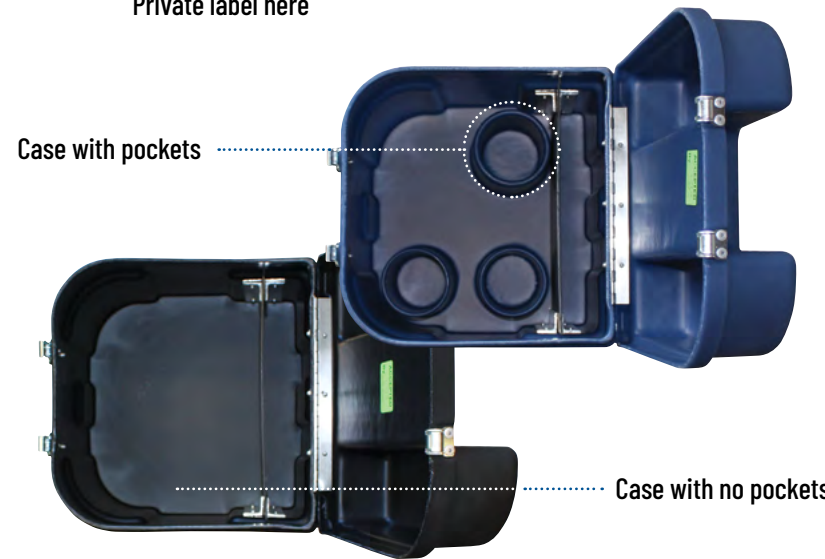

Case with pockets

Case with no pockets

ITEM #	DESCRIPTION	MODEL #	ORDER #
1	Gray - With Pockets	-	11008050
2	Black - With Pockets	-	11008051
3	Blue - With Pockets	-	11008052
4	Green - With Pockets	-	11008053
5	Red - With Pockets	-	11008054
6	Gray - No Pockets	-	11008055
7	Black - No Pockets	-	11008056
8	Blue - No Pockets	-	11008057
9	Green - No Pockets	-	11008058
10	Red - No Pockets	-	11008059

TECHNICIAN'S SERVICE CASES

B&G CARRY CASES

B&G CARRYING CASES ARE ROTATIONALLY MOLDED FOR YEARS OF DURABILITY.

FEATURES

- Seamless construction, no leaks
- Child-resistant lock
- Jumbo Case holds B&G Tank Sprayers and other equipment
- Contact B&G for color and sizes available

WHEELED JUMBO CASE

FEATURES

- Heavy duty aluminum frame
- Removable stainless handle
- Durable wheels

1 JUMBO CASE



2 JUNIOR CASE



3 WHEELED JUMBO CASE



ITEM #	DESCRIPTION	MODEL #	ORDER #
1	Compact Case with child-resistant lock - 16.5" x 9.75" x 16.5"	763 Grey	11008075
2	Jumbo case with child-resistant lock 16.75" x 14" x 19.25"	760 Grey	16016100
3	Jumbo Wheeled Carry Case	-	12011035

SERVICE CASES

B&G IPM KIT WITH ACCUSPRAY ELITE

The new IPM Case instantly lets your customer know that you are a professional. Use it to organize all your application tools.

FEATURES

- Outer zipper pocket holds frequently used items like insect monitors and bait stations
- Inner zipper compartment organizes bait tubes and bait gun
- Pockets on each side can hold Aerosols or AccuSpray units
- Inside the case can be customized using the adjustable dividers
- D-rings keep B&G Bulb Duster and accessories within reach
- Rear Velcro flap pocket



SERVICE CASES

CASE ONLY

Use your own IPM tools.



B&G IPM KITS

FEATURES

- Kit includes ADU, AccuSpray, Bulb Duster and Low Profile Monitors
- Bait Gun not included (shown for display purposes)



ITEM #	DESCRIPTION	MODEL #	ORDER #
1	IPM Kit with AccuSpray Elite	-	45000132
2	Case Only (No IPM Components)	-	45000165
3	IPM Kit with BASF ADU	-	45000151

Contact us to learn more:

800-544-8811

pelsis.com

135 Region South Drive,
Jackson, GA 30233

WE ARE  **pelsis**

A FAMILY OF BRANDS WITH ONE SHARED PURPOSE

B&G

CURTIS DYNA-FOG[®] _{Ltd.}

SYNERGETIC[®]

 **EDIALUX**
PROFESSIONAL PRODUCTS

NETWORK

P+L Systems[®]
Washroom

SILVANDERSSON 

AGRISENSE